



## LOW FORWARD VOLTAGE SCHOTTKY BARRIER RECTIFIER

### SRL3030P THRU SRL3060P

**VOLTAGE RANGE**      30 t o 60 Volts

**CURRENT**              30.0 Amperes

### FEATURES

- Schottky Barrier Chip
- Guard Ring Die Construction for Transient Protection
- Low Power Loss, High efficiency
- High Surge Capability
- High Current capacity and Low Forward Voltage Drop
- For use in low voltage high frequency inverters, Free wheeling, and polarity protection applications
- Plastic Material has UL Flammability Classification 94V-0

### MECHANICAL DATA

- Case: TO-3P(TO-247AD) molded plastic
- Terminals: Plated Lead solderable per MIL-STD-202 Method 208
- Polarity: See Diagram
- Weight: 5.6 grams (approx)
- Mounting Position: Any
- Marking: Type Number

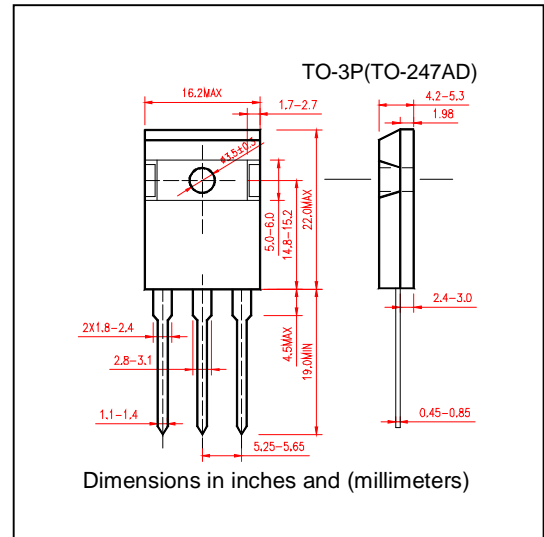

### MAXIMUM RATINGS AND ELECTRICAL CHARACTERISTICS

- Single Phase, half wave, 60Hz, resistive or inductive load
- For capacitive load derate current by 20%

	SYMBOLS	SRL 3030P	SRL 3035P	SRL 3040P	SRL 3045P	SRL 3050P	SRL 3060P	UNIT
Peak Repetitive Reverse Voltage	$V_{RRM}$	30	35	40	45	50	60	V
Working Peak Reverse Voltage	$V_{RWM}$							
DC Blocking Voltage	$V_R$							
RMS Reverse Voltage	$V_{R(RMS)}$	21	25	28	32	35	42	V
Average Rectified Output Current (Note 1)@ $T_c=95^\circ C$	$I_O$	30.0						A
Non-Repetitive Peak Forward Surge Current 8.3ms single half sine wave superimposed on rated load (JEDEC method)	$I_{FSM}$	275						A
Forward Voltage Drop @ $I_F=15A, T_c=25^\circ C$	$V_{FM}$	0.55				0.65		V
Peak Reverse Current at Rated DC Blocking Voltage	$T_c = 25^\circ C$	1.0						mA
	$T_c = 100^\circ C$	75						
Typical Junction Capacitance(Note2)	$C_j$	650						pF
Typical Resistance Junction to case(Note1)	$R_{\theta JC}$	1.5						$^\circ C/W$
Operating and Storage Temperature Range	$T_J T_{STG}$	(-55 to +150)						$^\circ C$

#### Notes:

1. Thermal Resistance Junction to case mounted on heatsink
2. Measured at 1.0MHz and applied reverse voltage of 4.0V DC



# LOW FORWARD VOLTAGE SCHOTTKY BARRIER RECTIFIER

**SRL3030P THRU SRL3060P**

**VOLTAGE RANGE** 30 to 60 Volts  
**CURRENT** 30.0 Amperes

## RATING AND CHARACTERISTIC CURVES SRL3030P THRU SRL3060P

